

F33 FDA



F33 FDA

- Designed for opening bags in bag filling stations.
- Also suitable to handle thin and sensitive sheets, such as paper and plastic films.
- The thin, conformable lip and clever cleat pattern prevent sensitive object/sheet to get sucked in and damaged while giving enhanced lifting force.
- FDA approved silicone material.

Lifting forces & Technical data

Lifting force vertical to the surface, N, at vacuum level			Lifting force parallel to the surface, N, at vacuum level			Volume	Min. curve radius	Max. vertical movement	Weight rubber part
20 -kPa	60 -kPa	90 -kPa	20 -kPa	60 -kPa	90 -kPa	cm ³	mm	mm	g
16	38	49	13.5	32.5	41.5	2.1	35	1.5	5.4

Material specifications

Material	Colour	Hardness °Shore A	Temperature range °C
Silicone, SIL FDA	Blue	50	-40–200

Material resistance

Material	Wear resistance	Oil	Weather & ozone	Hydrolysis	Petrol	Concentrated acids	Alcohol	Oxidation
Silicone, SIL FDA	Good	Poor	Excellent	Fair	Poor	Poor	Good	Excellent

Ordering information

Complete suction cups		Art. No.
A	Suction cup F33 Silicone FDA, 1/8" NPSF female	9914252
B	Suction cup F33 Silicone FDA, G1/4" male	9914237

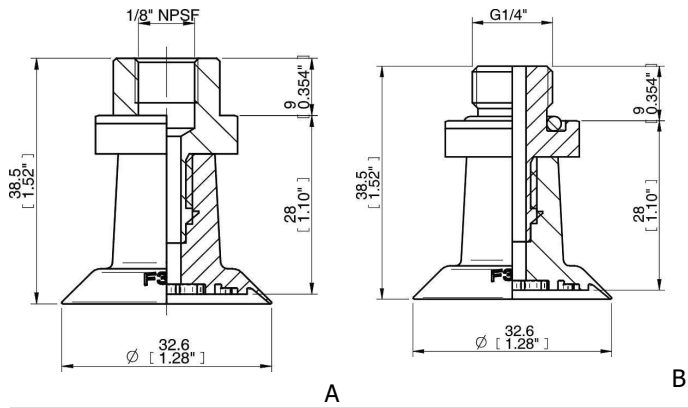

Rubber part

Suction cup F33 Silicone FDA		Art. No.
		0200328

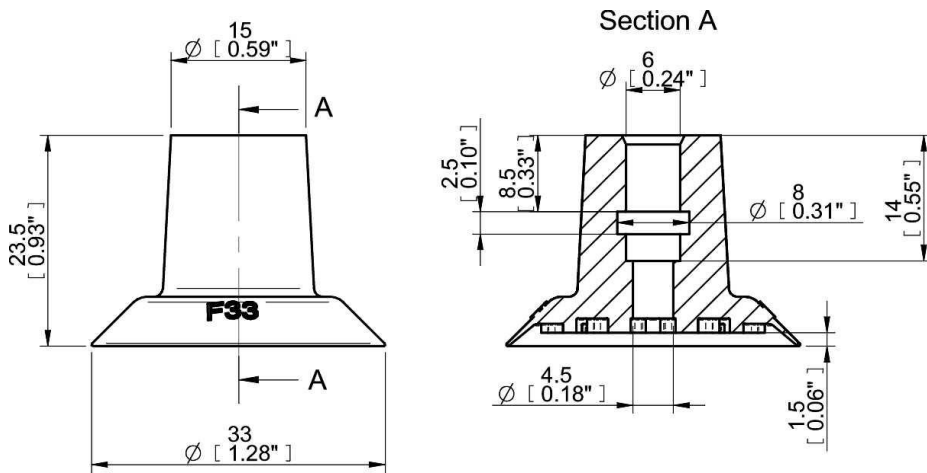

Fittings

Fittings		Art. No.
Fitting 1/8" NPSF female		0201969
Fitting G1/4" male		0201967